

# CliQ II DIN Rail Power Supply

## 48 V 240 W 1 Phase / DRP048V240W1B□



### Highlights & Features

- Universal AC input voltage range
- Power will not de-rate for the entire input voltage range
- Power Boost of 150% for 5 seconds
- Full corrosion resistant aluminium casing
- Conforms to harmonic current IEC/EN 61000-3-2, Class A
- Extreme low temperature cold start at -40°C
- Conformal coating on PCBAs to protect against common dust and chemical pollutants
- Hazardous Locations approval to ATEX and Class I, Div 2 (DRP048V240W1BA)
- Certified according to IEC/EN/UL 62368-1

### Safety Standards



CB Certified for worldwide use

**Model Number:** DRP048V240W1B□  
**Unit Weight:** 0.96 kg (2.12 lb)  
**Dimensions (H x W x D):** 121 x 85 x 124.1 mm  
 (4.76 x 3.35 x 4.86 inch)

### General Description

The CliQ II DIN rail power supply series from one of the world's leading power supply companies, Delta Electronics Group, offers output voltage of 48 V. These products are encased in rugged yet lightweight full aluminium body that can withstand shock and vibration according to IEC 60068-2 standard. The series of single phase products can operate over a wide temperature range of -25°C to +80°C. These products also feature universal AC input voltage range from 85 Vac to 264 Vac and the power will not de-rate throughout the entire range. Another great feature is the conformal coating on the PCBA which allows selected models to be certified to ATEX and Class I, Div 2 for use in hazardous locations. The design conforms to harmonic current emission IEC/EN 61000-3-2, Class A.

### Model Information

CliQ II DIN Rail Power Supply

Model Number	Input Voltage Range	Rated Output Voltage	Rated Output Current
DRP048V240W1B□	85-264 Vac (120-375 Vdc)	48 Vdc	5.00 A

### Model Numbering

DR	P	048V	240W	1	B	□
DIN Rail	Power Supply	Output Voltage	Output Power	Single Phase	CliQ II Series	A - Metal Case, with Class I, Div 2 N - Metal Case, without Class I, Div 2

# CliQ II DIN Rail Power Supply

## 48 V 240 W 1 Phase / DRP048V240W1B□

### Specifications

#### Input Ratings / Characteristics

Nominal Input Voltage	100-240 Vac
Input Voltage Range	85-264 Vac
Nominal Input Frequency	50-60 Hz
Input Frequency Range	47-63 Hz
DC Input Voltage Range*	120-375 Vdc
Input Current	< 2.50 A @ 115 Vac, < 1.30 A @ 230 Vac
Efficiency at 100% Load	> 90.0% @ 115 Vac, > 92.0% @ 230 Vac
Max Power Dissipation	0% load < 6.5 W @ 115 Vac, < 5.5 W @ 230 Vac
	100% load < 25 W @ 115 Vac, < 19 W @ 230 Vac
Max Inrush Current (Cold Start)	< 35 A @ 115 Vac & 230 Vac
Power Factor at 100% Load	> 0.96 @ 115 Vac, > 0.90 @ 230 Vac
Leakage Current	< 1 mA @ 240 Vac

\*Fulfills test conditions for DC input. Safety approval for DC input can be obtained upon request.

#### Output Ratings / Characteristics\*\*

Nominal Output Voltage	48 Vdc
Factory Set Point Tolerance	48 Vdc $\pm$ 1%
Output Voltage Adjustment Range	48-56 Vdc
Output Current	5.00 A (continuously operating at 48 V) 7.50 A (Power Boost for 5 seconds at 48 V, refer to the details in the Functions section)
Output Power	240 W (continuously operating at 48 V) 360 W (Power Boost for 5 seconds at 48 V, refer to the details in the Functions section)
Line Regulation	< 0.5% (@ 85-264 Vac input, 100% load)
Load Regulation	< 1.0% (@ 85-264 Vac input, 0-100% load)
PARD*** (20 MHz)	< 200 mVpp
Rise Time	< 200 ms @ nominal input (100% load)
Start-up Time	< 1,000 ms @ nominal input (100% load)
Hold-up Time	> 20 ms @ 115 Vac & 230 Vac (100% load)
Dynamic Response (Overshoot & Undershoot O/P Voltage)	$\pm$ 2% @ 85-264 Vac input, 10-100% load (Slew Rate: 0.1 A/ $\mu$ s, 50% duty cycle @ 5 Hz)
Start-up with Capacitive Loads	10,000 $\mu$ F Max

\*\*For power de-rating from 50°C to 80°C, see power de-rating on page 3.

\*\*\*PARD is measured with an AC coupling mode, 5 cm wires, and in parallel with 0.1  $\mu$ F ceramic capacitor & 47  $\mu$ F electrolytic capacitor.

# CliQ II DIN Rail Power Supply

## 48 V 240 W 1 Phase / DRP048V240W1B□

### Mechanical

Case Cover / Chassis	Aluminium	
Dimensions (H x W x D)	121 x 85 x 124.1 mm (4.76 x 3.35 x 4.86 inch)	
Unit Weight	0.96 kg (2.12 lb)	
Indicator	Green LED	DC OK
Cooling System	Convection	
Terminal	Input	3 Pins (Rated 300 V/15 A)
	Output	4 Pins (Rated 300 V/15 A)
Wire	Input / Output	AWG 18-12
Mounting Rail	Standard TS35 DIN Rail in accordance with EN 60715	
Noise (1 Meter from power supply)	Sound Pressure Level (SPL) < 40 dBA	

### Environment

Surrounding Air Temperature	Operating	-25°C to +80°C (Cold Start at -40°C)
	Storage	-40°C to +85°C
Power De-rating	Vertical Mounting	> 50°C de-rate power by 2.5% / °C
	Horizontal Mounting	> 40°C de-rate power by 2.5% / °C
Operating Humidity	5 to 95% RH (Non-Condensing)	
Operating Altitude	0 to 2,500 Meters (8,200 ft.)	
Shock Test	Non-Operating	IEC 60068-2-27, 30 G (300 m/S <sup>2</sup> ) for a duration of 18 ms, 1 time per direction, 2 times in total
Vibration	Non-Operating	IEC 60068-2-6, 10 Hz to 500 Hz @ 30 m/S <sup>2</sup> (3 G peak); displacement of 0.35 mm; 60 min per axis for all X, Y, Z direction
Bump Test	Operating	IEC 60068-2-29, Half Sine Wave: 10 G for a duration of 11 ms, 1,000 times per direction, 6,000 times in total
Over Voltage Category	III	According to IEC/EN 62477-1 / EN 60204-1 (clearance and creepage distances) and IEC 62103 (safety part)
Pollution Degree	2	

### Protections

Overvoltage	< 57 V, SELV Output, Hiccup Mode, Non-Latching (Auto-Recovery)
Overload / Overcurrent	> 150% of rated load current, Hiccup Mode, Non-Latching (Auto-Recovery)
Over Temperature	< 80°C Surrounding Air Temperature @ 100% load, Non-Latching (Auto-Recovery)
Short Circuit	Hiccup Mode, Non-Latching (Auto-Recovery when the fault is removed)
Internal Fuse at L pin	T 6.3 A H
Degree of Protection	IP20
Protection Against Shock	Class I with PE* connection

\*PE: Primary Earth

# CliQ II DIN Rail Power Supply

## 48 V 240 W 1 Phase / DRP048V240W1B□

### Reliability Data

MTBF	> 500,000 hrs. as per Telcordia SR-332 I/P: 115 Vac & 230 Vac, O/P: 100% load, Ta: 25°C
Expected Cap Life Time	10 years (115 Vac & 230 Vac, 50% load @ 40°C)

### Safety Standards / Directives

Electrical Equipment of Machines	EN/BS EN 60204-1 (over voltage category III)	
Electrical Equipment for Use in Electrical Power Installations	IEC/EN/BS EN 62477-1 / IEC 62103	
Safety Entry Low Voltage	SELV (IEC 60950-1)	
Overvoltage on Telecommunication Networks	TNV-1 circuit	
Electrical Safety	SIQ Bauart	EN 62368-1
	UL/cUL recognized	UL 60950-1 and CSA C22.2 No. 60950-1 (File No. E191395) UL 62368-1 and CSA C22.2 No. 62368-1 (File No. E191395)
	CB scheme	IEC 60950-1, IEC 62368-1
	BIS	IS 13252-1 (Part 1)
	BSMI	CNS 14336-1
	KC	K 60950-1
Industrial Control Equipment	UL/cUL listed	UL 508 and CSA C22.2 No. 107.1-01 (File No. E315355)
	CSA	CSA C22.2 No. 107.1-01 (File No. 181564)
Hazardous Location / ATEX (For DRP048V240W1BA)	cCSAus	CSA C22.2 No. 213-M1987 and ANSI / ISA 12.12.01 [Class I, Division 2, Group A, B, C, D T4, Ta= -25°C to +80°C (Vertical: > +50°C derating, Horizontal: > +40°C derating)]
	ATEX	EN 60079-0, EN 60079-15 [Ex II 3G Ex nA nC IIC T4 Gc, Ta= -25°C to +80°C (Vertical: > +50°C derating, Horizontal: > +40°C derating)]  Certificate No. EPS 12 ATEX 1 491 X
CE	In conformance with EMC Directive 2014/30/EU and Low Voltage Directive 2014/35/EU  For DRP048V240W1BA: In conformance with Equipment for explosive atmospheres (ATEX) directive 2014/34/EU	
UKCA	In conformance with Electrical Equipment (Safety) Regulations 2016 No. 1011 and The Electromagnetic Compatibility Regulations 2016 No. 1091	
Galvanic Isolation	Input to Output	4.0 KVac
	Input to Ground	1.5 KVac
	Output to Ground	1.5 KVac

# CliQ II DIN Rail Power Supply

## 48 V 240 W 1 Phase / DRP048V240W1B□

### EMC

Emissions (CE & RE)		Generic Standards: CISPR 32, EN/BS EN 55032, KN 32, CNS 13438, CISPR 11, EN/BS EN 55011, FCC Title 47: Class B
Component Power Supply for General Use		EN/BS EN 61204-3
Immunity		Generic Standards: EN/BS EN 55024, KN 35, EN/BS EN 61000-6-1, EN/BS EN 61000-6-2
Electrostatic Discharge	IEC 61000-4-2	Level 4 Criteria A <sup>1)</sup> Air Discharge: 15 kV Contact Discharge: 8 kV
Radiated Field	IEC 61000-4-3	Level 3 Criteria A <sup>1)</sup> 80 MHz-1 GHz, 10 V/M, 80% modulation (1 kHz) 1.4 GHz-2 GHz, 3 V/M, 80% modulation (1 kHz) 2 GHz-2.7 GHz, 1 V/M, 80% modulation (1 kHz)
Electrical Fast Transient / Burst	IEC 61000-4-4	Level 3 Criteria A <sup>1)</sup> 2 kV
Surge	IEC 61000-4-5	Level 3 Criteria A <sup>1)</sup> Common Mode <sup>2)</sup> : 2 kV Differential Mode <sup>3)</sup> : 1 kV
Conducted	IEC 61000-4-6	Level 3 Criteria A <sup>1)</sup> 150 kHz-80 MHz, 10 Vrms
Power Frequency Magnetic Fields	IEC 61000-4-8	Criteria A <sup>1)</sup> 30 A/Meter
Voltage Dips and Interruptions	IEC 61000-4-11	100% dip; 1 cycle (20 ms); Self Recoverable
Low Energy Pulse Test (Ring Wave)	IEC 61000-4-12	Level 3 Criteria A <sup>1)</sup> Common Mode <sup>2)</sup> : 2 kV Differential Mode <sup>3)</sup> : 1 kV
Harmonic Current Emission		IEC/EN/BS EN 61000-3-2, Class A
Voltage Fluctuation and Flicker		IEC/EN/BS EN 61000-3-3

1) Criteria A: Normal performance within the specification limits

2) Asymmetrical: Common mode (Line to earth)

3) Symmetrical: Differential mode (Line to line)

# CliQ II DIN Rail Power Supply

48 V 240 W 1 Phase / DRP048V240W1B□

## Block Diagram

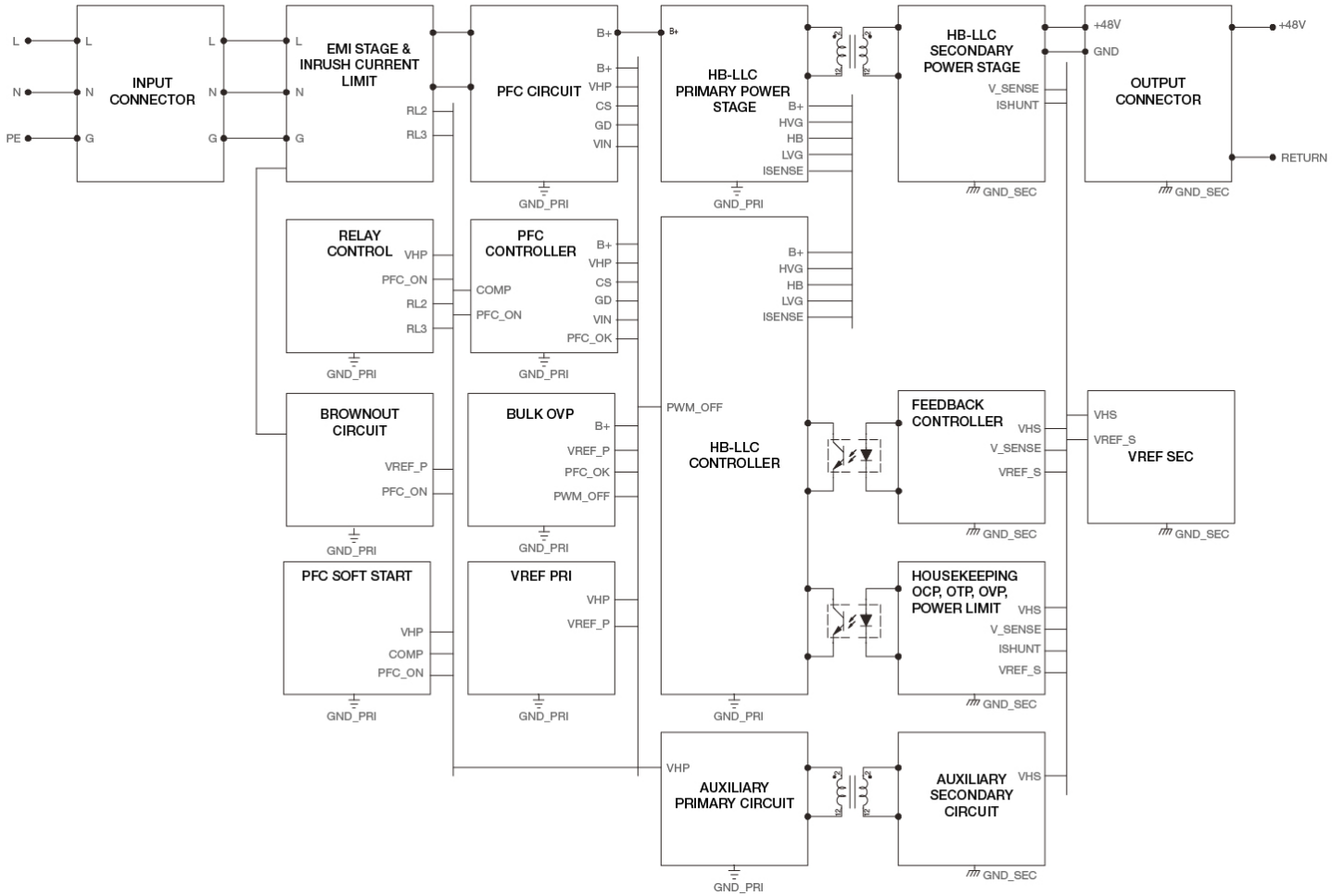

# CliQ II DIN Rail Power Supply

48 V 240 W 1 Phase / DRP048V240W1B□

## Device Description

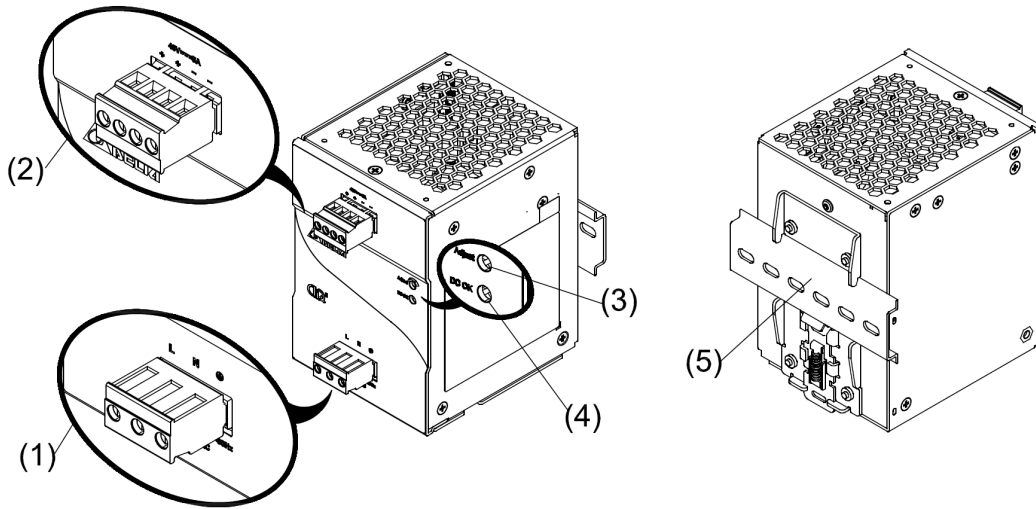

- 1) Input terminal block connector
- 2) Output terminal block connector
- 3) DC Voltage adjustment potentiometer
- 4) DC OK control LED (Green)
- 5) Universal mounting rail system

## Dimensions

H x W x D: 121 x 85 x 124.1 mm (4.76 x 3.35 x 4.86 inch)

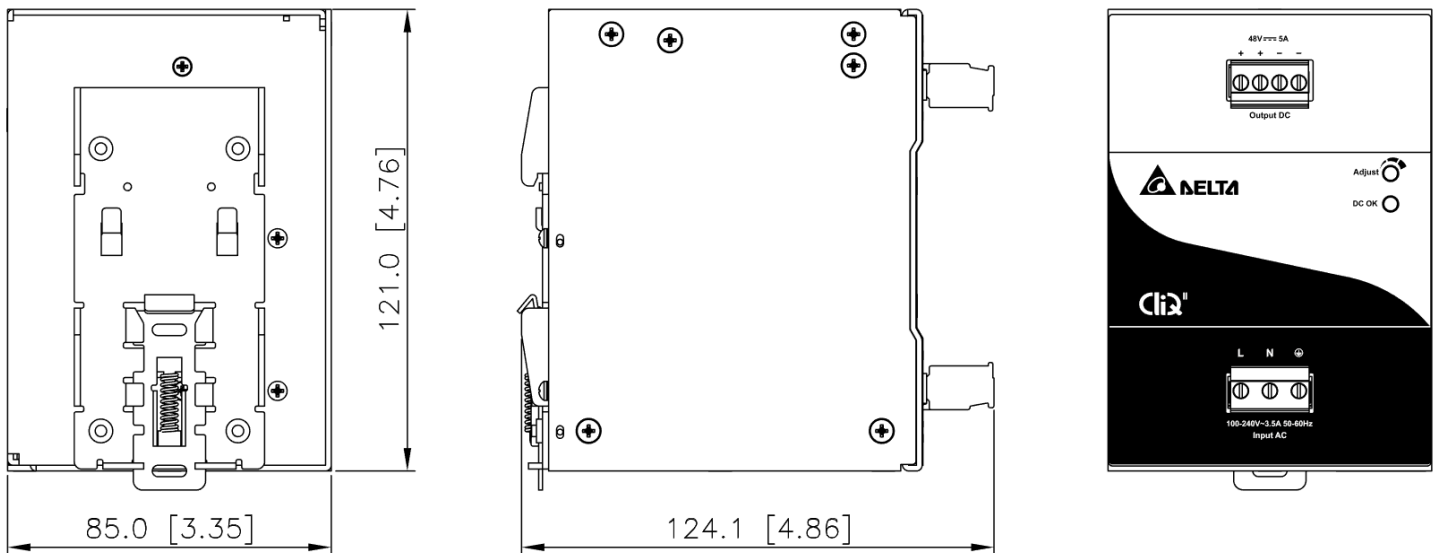

# CliQ II DIN Rail Power Supply

48 V 240 W 1 Phase / DRP048V240W1B□

## Engineering Data

### Output Load De-rating VS Surrounding Air Temperature

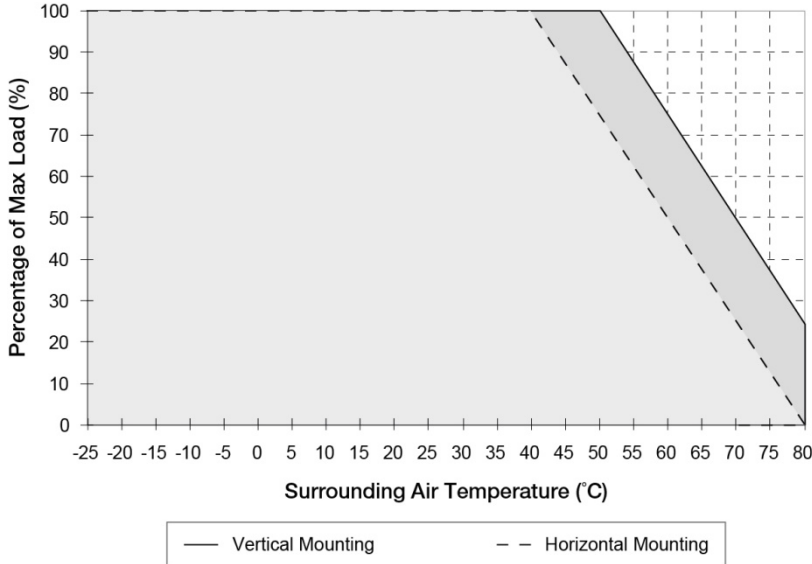

**Fig. 1 De-rating for Vertical Mounting Orientation**  
 > 50°C de-rate power by 2.5% / °C

**De-rating for Horizontal Mounting Orientation**  
 > 40°C de-rate power by 2.5% / °C

### Note

1. Power supply components may degrade, or be damaged, when the power supply is continuously used outside the shaded region, refer to the graph shown in Fig. 1.
2. If the output capacity is not reduced when the surrounding air temperature exceeds its specification as defined on Page 3 under "Environment", the device may run into Over Temperature Protection. When activated, the output voltage will go into bouncing mode and will recover when the surrounding air temperature is lowered or the load is reduced as far as necessary to keep the device in working condition.
3. In order for the device to function in the manner intended, it is also necessary to keep a safety distance as recommended in the safety instructions while the device is in operation.
4. Depending on the surrounding air temperature and output load delivered by the power supply, the device can be very hot!
5. If the device has to be mounted in any other orientation, please leave a message via the [Contact Us](#) form.

### Output Load De-rating VS Input Voltage

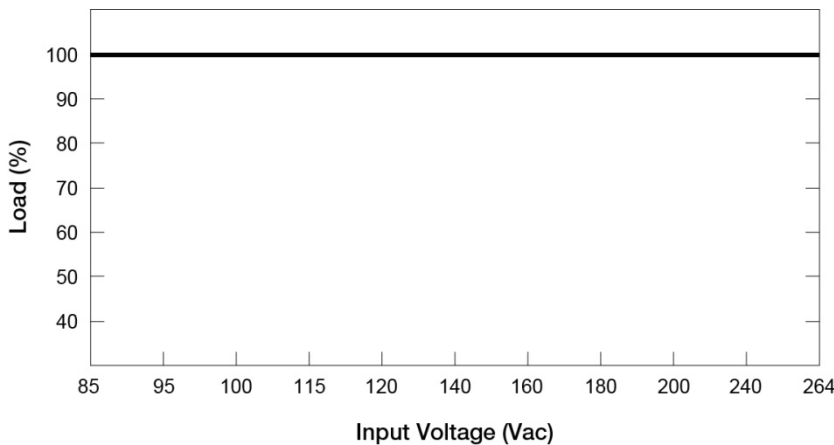

- No output power de-rating across the entire input voltage range



# CliQ II DIN Rail Power Supply

48 V 240 W 1 Phase / DRP048V240W1B□

## Assembly & Installation

The power supply unit (PSU) can be mounted on 35 mm DIN rails in accordance with EN 60715. The device should be installed with input terminal block at the bottom.

Each device is delivered ready to install.

### Mounting

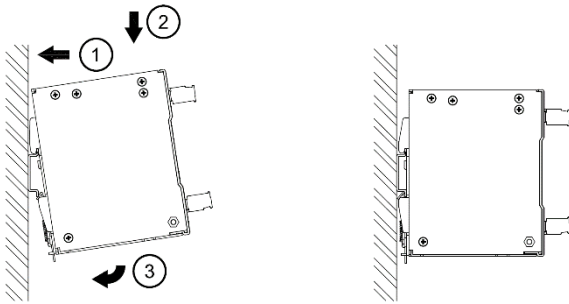

Fig. 2.1 Mounting

Snap on the DIN rail as shown in Fig. 2.1:

1. Tilt the unit upwards and insert it onto the DIN rail.
2. Push downwards until stopped.
3. Press against the bottom front side for locking.
4. Shake the unit slightly to ensure that it is secured.

### Dismounting

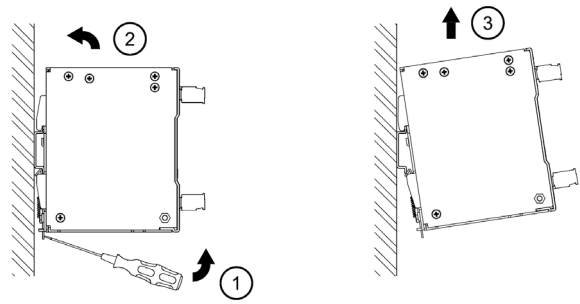

Fig. 2.2 Dismounting

To uninstall, pull or slide down the latch with screw driver as shown in Fig. 2.2. Then slide the power supply unit (PSU) in the opposite direction, release the latch and pull out the power supply unit (PSU) from the rail.

### Connection

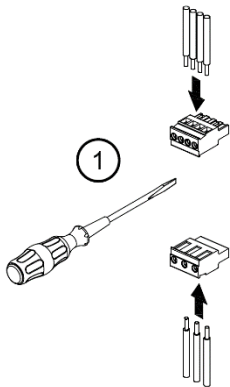

Fig. 3.1

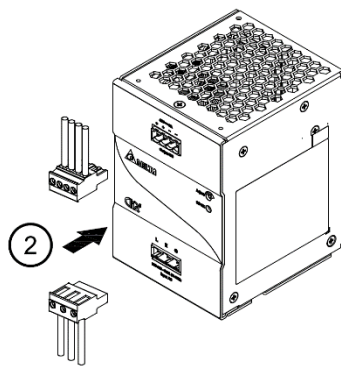

Fig. 3.2

**CAUTION:** Must tighten wire to housing (Fig. 3.1) before plugging into the terminal block connection (Fig. 3.2).

In accordance to EN 60950 / UL 60950 and EN 62368 / UL 62368, flexible cables require ferrules. Use appropriate copper cables designed to sustain operating temperature of:

1. 60°C, 60°C / 75°C for USA
2. At least 75°C for ambient not exceeding 60°C, and 90°C for ambient exceeding 60°C for Canada.

# CliQ II DIN Rail Power Supply

## 48 V 240 W 1 Phase / DRP048V240W1B□

### Safety Instructions

#### ■ Vertical Mounting

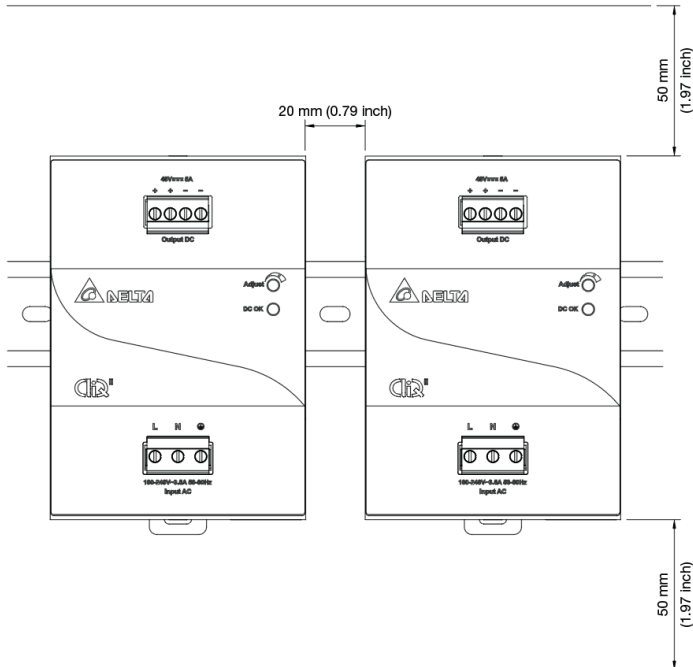

#### ■ Horizontal Mounting

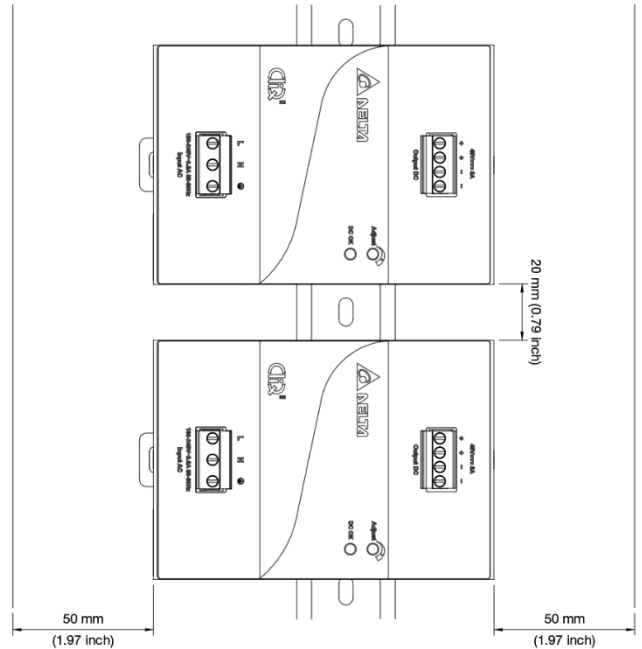

- ALWAYS switch mains of input power OFF before connecting and disconnecting the input voltage to the unit. If mains are not turned OFF, there is risk of explosion / severe damage.
- To guarantee sufficient convection cooling, please refer to the following instructions to ensure sufficient clearance around the device.  
**Vertical Mounting:** 50 mm (1.97 inch) above and below the device as well as a lateral distance of 20 mm (0.79 inch) to other units.  
**Horizontal Mounting:** 20 mm (0.79 inch) above and below the device as well as a lateral distance of 50 mm (1.97 inch) to other units.
- Note that the enclosure of the device can become very hot depending on the surrounding air temperature and load of the power supply. Risk of burns!
- Only plug in and unplug connectors when power is turned off!
- DO NOT insert any objects into the unit.
- Hazardous voltages may be present for up to 5 minutes after the input mains voltage is disconnected. Do not touch the unit during this time.
- The power supplies are built in units and must be installed in a cabinet or room (condensation free environment and indoor location) that is relatively free of conductive contaminants.
- CAUTION: "For use in a controlled environment".

#### For DRP048V240W1BA:

- The power supplies unit must be installed in an IP54 enclosure or cabinet in the final installation. The enclosure or cabinet must comply with EN 60079-0 or EN 60079-15.
- Warning: Explosion Hazard - Substitution of components may impair suitability for Class I, Division 2.
- Warning: Explosion Hazard - Do not disconnect equipment or adjust potentiometer unless the power has been switched off or the area is known to be non-hazardous.

# CliQ II DIN Rail Power Supply

48 V 240 W 1 Phase / DRP048V240W1B□

## Functions

- Graph illustrating the Start-up Time, Rise Time, and Hold-up Time



## Start-up Time

The time required for the output voltage to reach 90% of its final steady state set value, after the input voltage is applied.

## Rise Time

The time required for the output voltage to change from 10% to 90% of its final steady state set value.

## Hold-up Time

Time between the collapse of the AC input voltage, and the output falling to 95% of its steady state set value.

## Inrush Current

Inrush current is the peak, instantaneous, input current measured and, occurs when the input voltage is first applied. For AC input voltages, the maximum peak value of inrush current will occur during the first half cycle of the applied AC voltage. This peak value decreases exponentially during subsequent cycles of AC voltage.

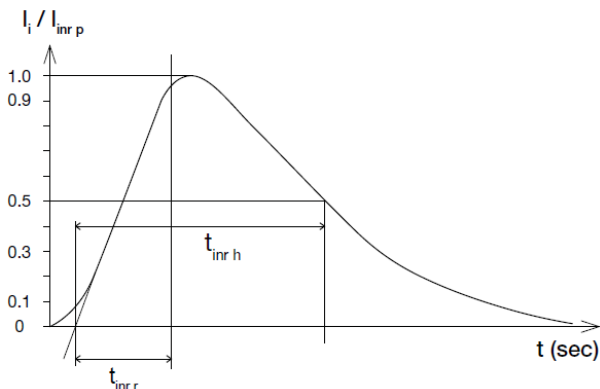

## Dynamic Response

The power supply output voltage will remain within  $\pm 2\%$  of its steady state value, when subjected to a dynamic load from 10% to 100% of its rated current.

- 50% duty cycle / 5 Hz

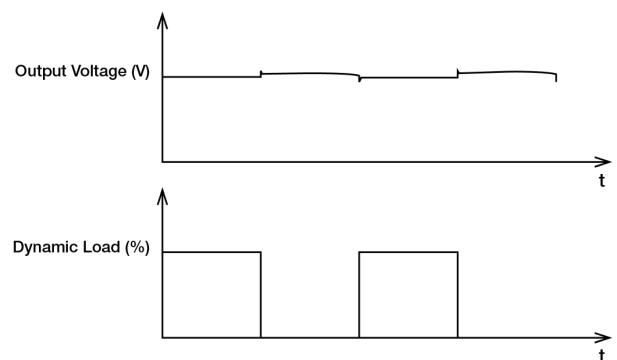

# CliQ II DIN Rail Power Supply

48 V 240 W 1 Phase / DRP048V240W1B□

## Power Boost

Power Boost is the reserve power available constantly that allows reliable startup to support sudden and short spike of loads with high inrush current typically during turn on to remove the need of more expensive higher rated power supply unit. After the output has reached its steady state set value, the power supply can support surge loads with a higher short-term power demand up to 150% of maximum rated load ( $I_o$  Max), for a maximum duration of 5 seconds. The Power Boost is also available to repeatedly basis with according to the condition of an average (R.M.S) output power shall not exceed continuous operating condition or refer to duty cycle calculation below.

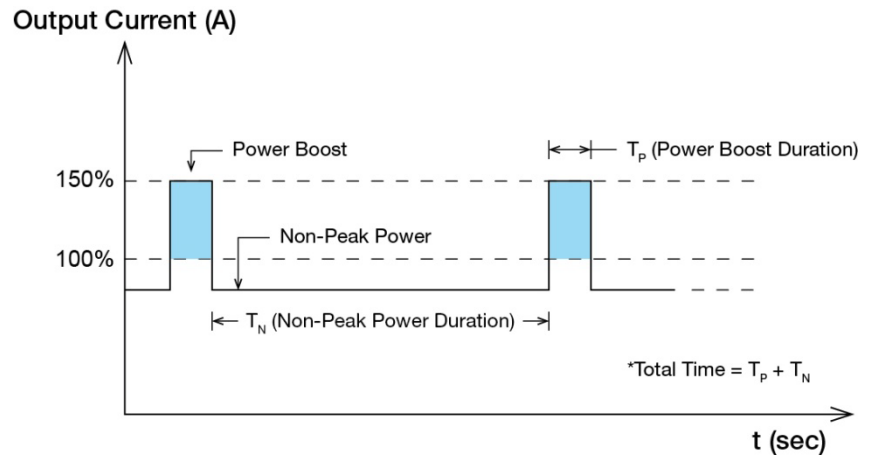

Fig. 4 Duty Cycle Calculation

$$\text{Duty cycle (\%)} = \frac{T_p}{\text{Total Time}}$$

$$\text{Average Output Power (P}_{Avg}\text{)} = \frac{(\text{Power Boost} \times T_p) + (\text{Non-Peak Power} \times T_N)}{\text{Total Time}}$$

OR

$$\text{Non-Peak Power} = \frac{(\text{P}_{Avg} \times \text{Total Time}) - (\text{Power Boost} \times T_p)}{T_N}$$

### ■ An example of Power Boost and Average Output Power

Power Boost	Peak Power (W <sub>P</sub> )	Power Boost Duration (T <sub>P</sub> )	Duty Cycle	Non-Peak Power (W <sub>N</sub> )	Non-Peak Power Duration (T <sub>N</sub> )	Total Time (T)
150%	360	5 sec	10%	226 W	45 sec	50 sec
150%	360	5 sec	35%	175 W	9.3 sec	14.3 sec
120%	288	10 sec	20%	228 W	40 sec	50 sec
120%	288	10 sec	35%	214 W	18.5 sec	28.5 sec

It is not recommended to prolong the duration of Power Boost to be longer than the specified duty cycle calculation, this may cause damage to the PSU.

## External Input Protection Device

The unit is protected with internal fuse (not replaceable) at L pin and it has been tested and approved on 20 A (UL) and 16 A (IEC) branch circuits without additional protection device. An external protection device is only required if the supplying branch has an ampacity greater than above. Thus, if an external protective device is necessary, or, utilized, please refer a minimum value of 8 A B- or 6 A C- characteristic breaker.

# CliQ II DIN Rail Power Supply

48 V 240 W 1 Phase / DRP048V240W1B□

## Overload & Overcurrent Protections (Auto-Recovery)

The power supply's Overload (OLP) and Overcurrent (OCP) Protections will be activated when output current exceeds its specification as defined on Page 3 under "Protections". In such occurrence, the  $V_O$  will start to droop and once the power supply has reached its maximum power limit, the protection is activated and the power supply will go into "Hiccup mode" (Auto-Recovery). The power supply will recover once the fault condition of the OLP and OCP is removed and  $I_O$  is back within the specifications.

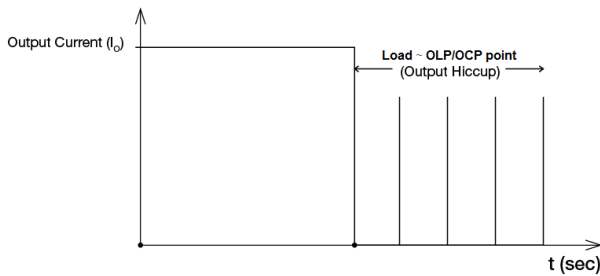

It is not recommended to prolong the duration of  $I_O$  when it is less than OLP/OCP point, but greater than 100%, since it may cause damage to the PSU.

## Short Circuit Protection (Auto-Recovery)

The power supply's output OLP/OCP function also provides protection against short circuits. When a short circuit is applied, the output current will operate in "Hiccup mode", as shown in the illustration in the OLP/OCP section on this page. The power supply will return to normal operation after the short circuit is removed.

## Overvoltage Protection (Auto-Recovery)

The power supply's overvoltage circuit will be activated when its internal feedback circuit fails. The output voltage shall not exceed its specifications defined on Page 3 under "Protections".

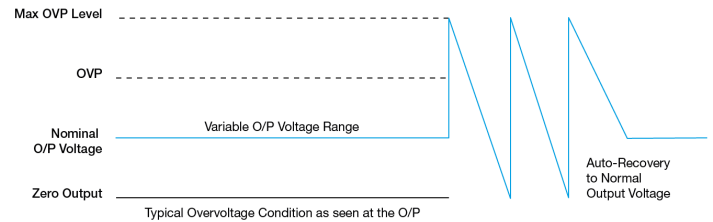

## Over Temperature Protection (Auto-Recovery)

As described in load de-rating section, the power supply also has Over Temperature Protection (OTP). In the event of a higher operating temperature at 100% load, the power supply will run into OTP when the operating temperature is beyond what is recommended in the de-rating graph. When activated, the output voltage will go into bouncing mode until the temperature drops to its normal operating temperature as recommended in the de-rating graph.

# CliQ II DIN Rail Power Supply

48 V 240 W 1 Phase / DRP048V240W1B□

## Operating Mode

### ■ Redundant Operation

In order to ensure proper redundant operation for the power supply unit (PSU), the output voltage difference between the two units must be kept at 0.90~1.00 V for 48 V supplies. Follow simple steps given below to set them up for the redundant operation:

#### Step 1.

Measure output voltage of PSU 1 and PSU 2. If PSU 1 is the master unit, then  $V_O$  of PSU 1 must be higher than PSU 2. In order to set the output voltage, individually connect the power supply to 50% of rated load at any line voltage, and set the PSU 1 and PSU 2 output voltage.

#### Step 2.

Connect the power supply units PSU 1 and PSU 2 to  $V_{in 1}$  &  $V_{in 2}$ , respectively, of the DRR-20N (or 20A) module shown on the diagram on the right.

#### Step 3.

Connect the system load from  $V_{out}$ . Please note that output voltage  $V_{out}$  from DRR module will be  $= V_O$  (output voltage of power supply)  $- V_{drop}^*$  (in DRR module).

\* $V_{drop}$  will vary from 0.60 V to 0.90 V (Typical 0.65 V) depending on the load current and surrounding air temperature.

### ■ Parallel Operation

The power supply units (PSUs) can also be used for parallel operation in order to increase the output power. The difference in output voltage between the two units must be kept to within 25 mV of each other. This difference must be verified with the same output load connected independently to each unit.

Parameters such as EMI, inrush current, leakage current, PARD, start up time will be different from those on the datasheet, when two units are connected in parallel. The user will need to verify that any differences will still allow the two power supplies connected in parallel will work properly in their product/application.

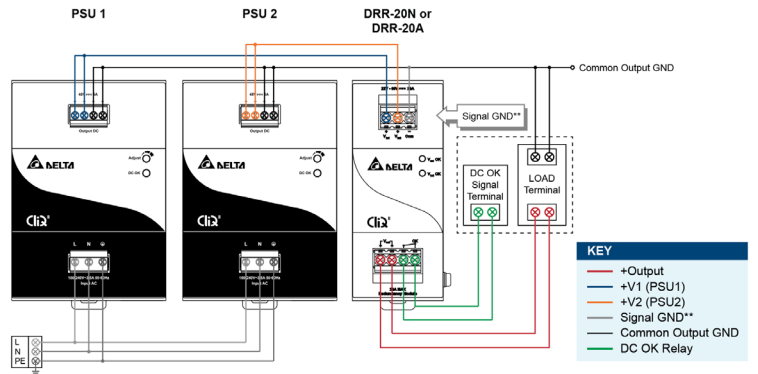

\*\*The Signal GND in the DRR module is for the built-in LED and DC OK signals. The Output GND terminals from the two PSU's do not need to be connected to the Signal GND terminal.

Fig. 5 Redundant Operation Connection Diagram

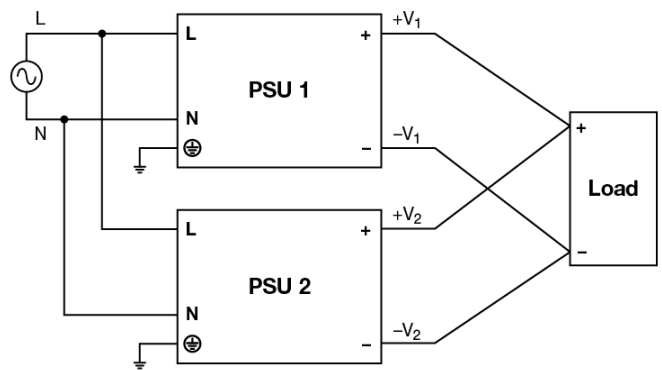

Fig. 6 Parallel Operation Connection Diagram

# CliQ II DIN Rail Power Supply

48 V 240 W 1 Phase / DRP048V240W1B□

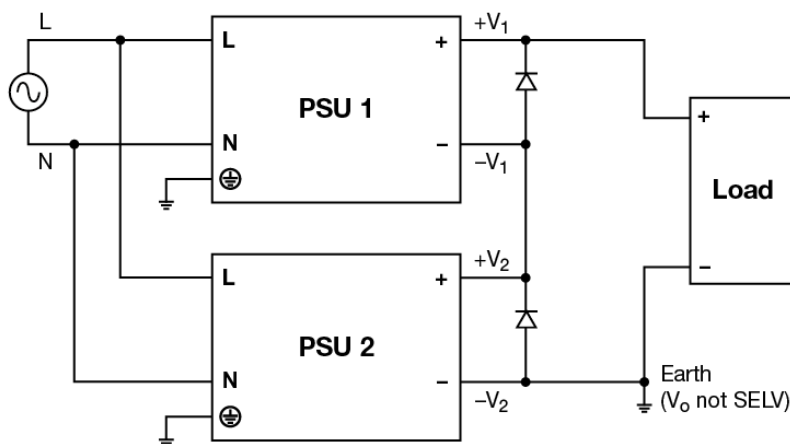

Fig. 7 Series Operation Connection Diagram

## Series Operation

Delta's CliQ II can be connected in series to increase the output voltage as shown in figure above. Power supply from the same product series only be used and with the same rated output current. The maximum load current should not exceed the smallest rated output current. Any number of power supplies can be connected in series, user must note that output voltage > 60 Vdc will not meet SELV requirements and could be hazardous to user the total voltage shall not exceed 150 Vdc. Installing a protection against the touching is must and connect the output ground to earth when output voltage is not SELV.

A diode in reverse bias must be added across output terminals of each power supply, this is to prevent -V voltage being applied to other power supply in fault conditions such as short circuit across load. During short circuit -V<sub>1</sub> & +V<sub>1</sub> will come across +V<sub>2</sub> & -V<sub>2</sub> which means connecting 2 power supplies in opposite polarity and may cause damage to the power supply. With reverse bias diodes in place the voltage across each power supply will be restricted to one diode drop – approximately 0.7 V to 1.0 V.

It is recommended to provide sufficient de-rating for diodes hence it is recommended to use 2 times the voltage rating of the output voltage or equal to the rating of series output depending which is higher, e.g. 48 V power supply can use 96 V rated diode which is equal to two 48 V power supplies connected in series OR a 48V power supply adjusted to 56 V output will see 56 V + 56 V = 112 V, in this case reverse voltage rating of diode shall be > 112 V.

During the short circuit condition, the current through diodes will be large, hence it is recommended that diodes to be least twice the current rating of the power supply.

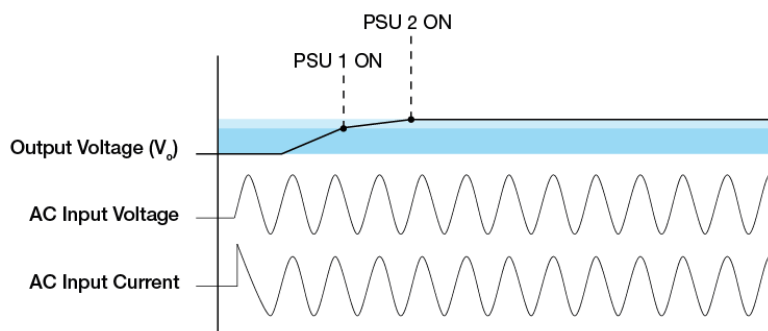

The turn ON would be non-monotonic as the power supply with the fastest startup time and rise time will turn on first. As a result, the startup waveform with 2 power supplies connected in series would see a step.

User must consider to verify parameters such as EMI, inrush current, leakage current, PARD, startup time would differ from datasheet numbers as multiple power supplies in series.

# CliQ II DIN Rail Power Supply

48 V 240 W 1 Phase / DRP048V240W1B□

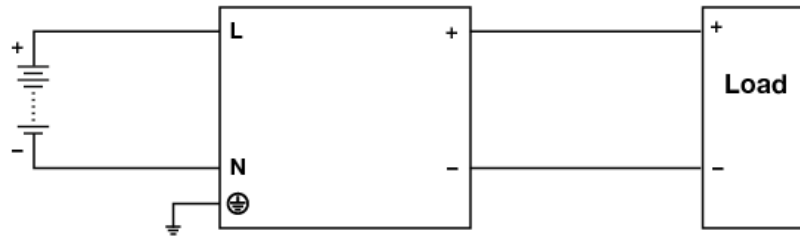

Fig. 8 DC Input Operation Connection Diagram

## ■ DC Input Operation

### Step 1.

Use a battery or similar DC source.

### Step 2.

Connect +pole to L and -pole to N.

### Step 3.

Connect the PE terminal to an earth wire or to the machine ground.

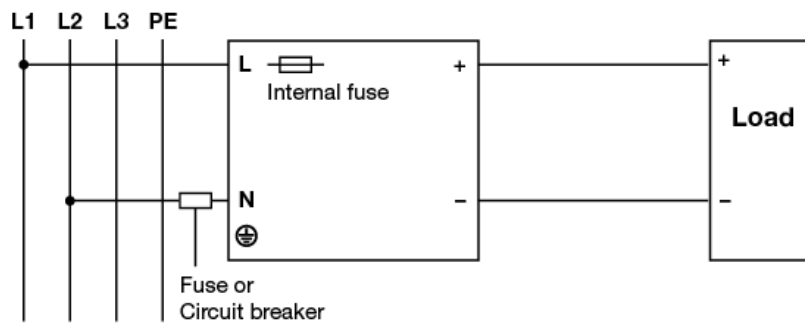

Fig. 9 2 of 3 Phase System Input Operation Connection Diagram

## ■ 2 of 3 Phase System Input Operation

Delta's CliQ II can use on 2 of 3 phase system. Please refer to the following step.

### Step 1.

The input voltage applied from Line to Neutral is below the maximum rated input. The input voltage shall be below 240 Vac +10%.

### Step 2.

The external protector is needed on N (Neutral) input line to secure a safety. N line does not have internal fuse protection. An appropriate fuse or circuit breaker should be connected in series with N input line connection like the following.



# CliQ II DIN Rail Power Supply

## 48 V 240 W 1 Phase / DRP048V240W1B□

### Others

#### Conformal Coating

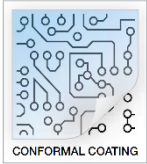

#### The Protective Coating Technology

Delta Electronics Group has designed the perfect dipping technique which penetrates everywhere including under device, and prevents leakage. The conformal coating dipping can be applied to PCBAs or circuit board. The coating preserves the performance of precision electronic primarily by preventing ionizable contaminants such as salt from reaching circuit nodes, where the material slumps around sharp edges. This can be a problem especially in highly conversing atmosphere.

#### PFC – Norm EN 61000-3-2

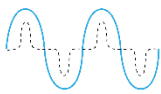

#### Line Current Harmonic content

Typically, the input current waveform is not sinusoidal due to the periodic peak charging of the input capacitor. In industrial environments, compliance with EN 61000-3-2 is only necessary under special conditions. Complying to this standard can have some technical drawbacks, such as lower efficiency; and, can also result in higher product cost. Frequently, the user does not profit from compliance to this standard; therefore, it is important to know whether it is mandatory to meet this standard for a specific application.

### Attention

Delta provides all information in the datasheets on an “AS IS” basis and does not offer any kind of warranty through the information for using the product. In the event of any discrepancy between the information in the catalog and datasheets, the datasheets shall prevail (please refer to [www.DeltaPSU.com](http://www.DeltaPSU.com) for the latest datasheets information). Delta shall have no liability of indemnification for any claim or action arising from any error for the provided information in the datasheets. Customer shall take its responsibility for evaluation of using the product before placing an order with Delta.

Delta reserves the right to make changes to the information described in the datasheets without notice.

### Manufacturer and Authorized Representatives Information

#### Manufacturer

##### Thailand

Delta Electronics (Thailand) PCL.  
909 Pattana 1 Rd., Muang, Samutprakarn, 10280 Thailand

##### Taiwan

Delta Electronics, Inc.  
3 Tungyuan Road, Chungli Industrial Zone, Taoyuan County  
32063, Taiwan

#### Authorized Representatives

##### The Netherlands

Delta Greentech (Netherlands) B.V.  
Zandsteen 15, 2132 MZ Hoofddorp, The Netherlands

##### United Kingdom

Delta Electronics Europe Limited  
1 Redwood Court, Peel Park Campus,  
East Kilbride, Glasgow, G74 5PF, United Kingdom