

Medical / Industrial AC-DC Power Supply

750 W with 5 V / 2 A Standby / MEB-750A series



Highlights & Features

- Up to 750 Watt in 4" x 7" x 1.575" Package
- Up to 17 W/inch³ Power Density
- Full Power from 90 V to 264 V
- Full Power up to 50°C Ambient
- Peak Power Boost up to 1200 W (48 V model)
- Up to 500 KHrs MTBF
- 2 x MOPP Isolation
- Suited for Type BF Medical Products.
- 5 V / 2 A Standby Output
- Current Sharing
- Conformal Coating
- Class B Conducted and Radiated EMI
- IEC 60601-1-2 4th Edition Immunity Compliance
- Normal and Reversed Option for Remote On/Off and Power Good Signal
- Voltage Trimming

Safety Certifications

- IEC 60601-1 CB report
- TUV EN 60601-1
- ANSI/AAMI ES 60601-1 +CAN/CSA-C22.2 No.60601-1
- IEC 60950-1 CB report
- IEC 62368-1 CB report
- IEC 60335-1 CB report (12V / 24V model)
- IEC 61558-1 CB report (12V / 24V model)
- IEC 61558-2-16 CB report (12V / 24V model)
- TUV EN 62368-1
- TUV EN 60335-1 (12V / 24V model)
- TUV EN 61558-1 (12V / 24V model)
- TUV EN 61558-2-16 (12V / 24V model)
- UL 62368-1 and CAN/CSA C22.2 No. 62368-1
- CCC GB 17625.1; GB 4943.1; GB/T 9254.1 (24V / 48V model)
- KC/KCC (24V model)

Input			
Input Voltage	85 VAC ~ 264 VAC		
Input Frequency	47 Hz ~ 63 Hz		
Input Current	<9 A		
Inrush Current	<40 A		
Power Factor	>0.95 @ rated load		
Efficiency	Up to 94% ¹⁾		
Patient Leakage Current	<100 uA normal, <500 uA SFC		
Earth Leakage Current	<300 uA normal, <1 mA SFC		
Output			
Output Voltage	12 V	24 V	48 V
Output Current	0-58.4 A	0-31.25 A	0-15.63 A
Ripple & Noise	<1% Vrated pk-pk		
Standby Power	5 V / 2 A (No minimum load required)		
Environmental			
MTBF	500 KHrs		
Operation Temperature	-20°C ~70°C ²⁾		
Operation Altitude	5000 m or 54 kPa		

1) Exclude fan power

2) Power de-rating with temperature above 50°C, refer to power de-rating curve for detail

Medical / Industrial AC-DC Power Supply

750 W with 5 V / 2 A Standby / MEB-750A series

Model Information (With 5 V / 2 A standby available)

Model Number	Input Voltage	Output Voltage	Current Output
MEB-750A12B	85 Vac	12 Vdc	0-52.08 A
MEB-750A12T	90-264 Vac	12 Vdc	0-58.4 A
MEB-750A24B	85 Vac	24 Vdc	0-26.04 A
MEB-750A24T	90-264 Vac	24 Vdc	0-31.25 A
MEB-750A48B	85 Vac	48 Vdc	0-13.02 A
MEB-750A48T	90-264 Vac	48 Vdc	0-15.63 A

Model Numbering

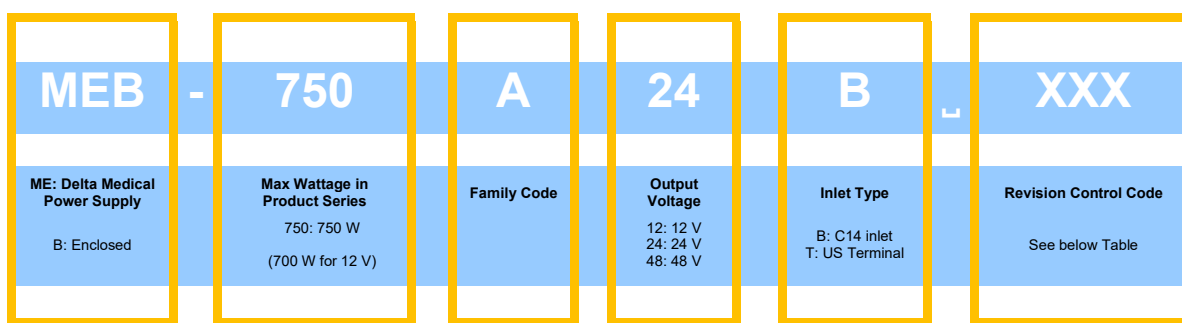

Revision Control Code

Revision Control Code	Package
AAA	Delta Standard

Medical / Industrial AC-DC Power Supply

750 W with 5 V / 2 A Standby / MEB-750A series

Specifications

Input Ratings / Characteristics

Nominal Input Voltage	100-240 Vac	
Input Voltage Range	85-264 Vac	
Nominal Input Frequency	50-60 Hz	
Input Frequency Range	47-63 Hz	
Input Current (max)	9 A	
Input Surge Voltage (max)	300 Vac for 100 ms	
Full load Efficiency (typ.) (Exclude fan power)	For 12 V output model	88% @ 115 Vac / 60 Hz 90.5% @ 230 Vac / 50 Hz, Reference Fig. 1
	For 24 V output Model	92% @ 115 Vac / 60 Hz 94% @ 230 Vac / 50 Hz Reference Fig. 2
	For 48 V output Model	91.5% @ 115 Vac / 60 Hz 94% @ 230 Vac / 50 Hz Reference Fig. 3
Inrush Current (max)	40 A @ 264 Vac, cold start	
Input-PE (protective earth) leakage current (typ.)	0.3 mA @ NC, 1 mA @ SFC ¹⁾	
Output-PE (protective earth) leakage current for Type BF application (max)	0.1 mA @ NC, 0.5 mA @ SFC ¹⁾	
Power Factor (min)	0.95 @ 115 V / 50 Hz, 230 V / 50 Hz, full load	

1) NC: normal condition, SFC: single fault condition

Leakage Current

Input-PE Leakage Current	100 Vac / 60 Hz(Typ)	264 Vac / 60 Hz(Typ)	Delta Limit	IEC60601-1 Limit
Normal Condition	108.5 uA	289.3 uA	300 uA max	5000 uA max
Single Fault Condition	211.4 uA	561.3 uA	1000 uA max	10000 uA max
Output-PE Leakage Current for Type BF application				
Normal Condition	34 uA	89 uA	100 uA max	100 uA max
Single Fault Condition	70 uA	185 uA	500 uA max	500 uA max

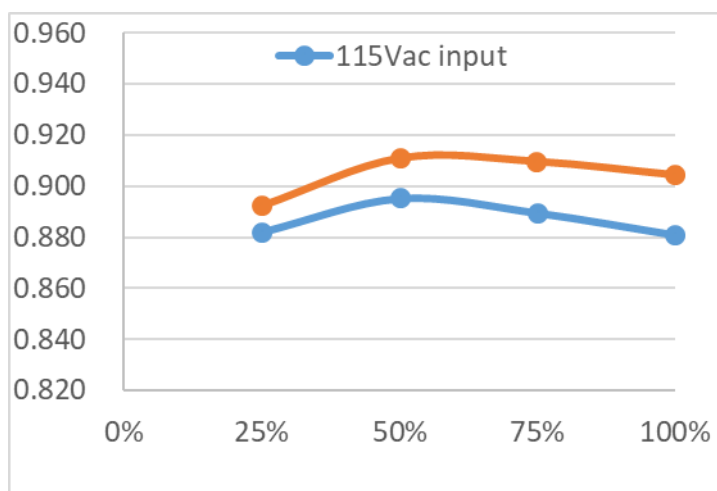

Figure 1. Typical efficiency Curve for 12 V (exclude fan power)

Medical / Industrial AC-DC Power Supply

750 W with 5 V / 2 A Standby / MEB-750A series

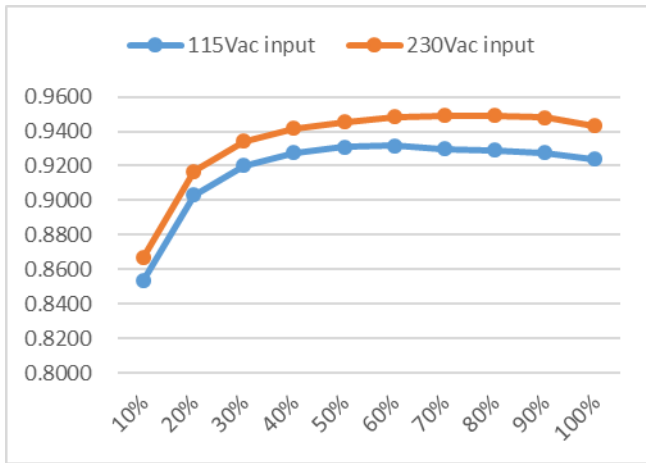

Figure 2. Typical efficiency Curve for 24 V (exclude fan power)

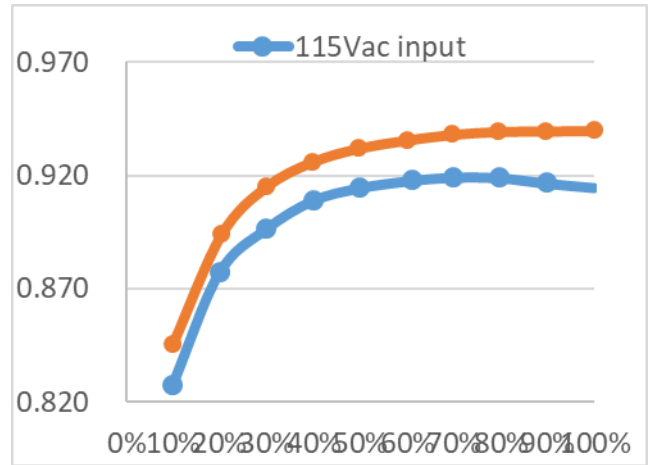

Figure 3. Typical efficiency Curve for 48 V (exclude fan power)

Output Ratings / Characteristics

Total Regulation		± 3%
Output Power (max)	For 12 V output Model	700 W
	For 24 V/ 48 V output Model	750 W
Peak Power (max)	For 48 V output Model	1200 W peak for 0.5 sec, 0-25 A, Slew rate 0.1 A/ms, above 100 Vac
Line Regulation (max)		1%
Load Regulation (max)		2%
Ripple & Noise (typ.)		1% pk-pk Vrated@ rated load, Reference Fig. 4
Voltage Trimming Range	For 12 V output Model	12-14V
	For 24 V/ 48 V output Model	± 10% Vrated
Dynamic Response (Overshoot & Undershoot O/P Voltage)		± 5% @ with 50% load change
Start-up Time (max)		2000 ms with AC turn on
Hold-up Time (min)		12 ms @ 100% load, with nominal input range
Capacitive load (max)		6000 uF
Rise time (max)		<50 ms
Remote Sense		Up to 500 mV compensation for voltage drop across external wire connections to load. Short and reverse connection protected.



(a) 115 V (measured value=187 mV)



(b) 230 V (measured value=171 mV)

Figure 4. 24 V output model Ripple & Noise example, 20 MHz BW

Medical / Industrial AC-DC Power Supply

750 W with 5 V / 2 A Standby / MEB-750A series

Nominal Output Voltage of standby output (Vrated) ¹⁾	5 V
Nominal Output Current of standby output	2 A
Total Regulation of standby output	± 3%
Ripple & Noise of standby output	100 mV max

1) 5V standby output is always on when AC is present

Ripple & Noise measurement circuit

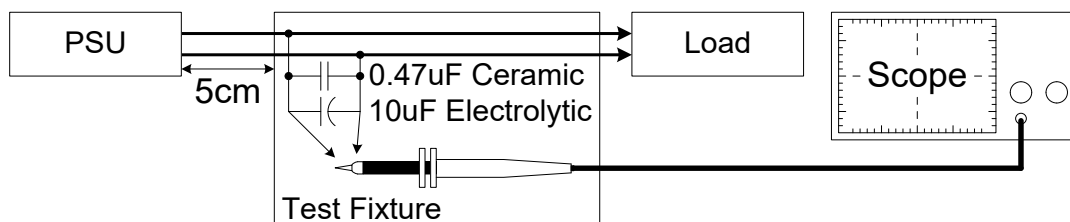

Figure 5. Ripple & Noise testing set up

Mechanical

Package	Enclosed
Dimensions (L x W x H)	177.8 x 101.6 x 40 mm (7 x 4 x 1.575 inch)
Unit Weight	1.1 kg (2.4 lb)

Environment

Surrounding Air Temperature	Operating	Absolute Maximum/Minimum Rating. -20°C to +70°C. Linear power derate from 100% load at 50°C, to 50% load at 70°C Note: see power de-rating curves below
	Storage	-40°C to +85°C
Operating Humidity	5-95% RH (Non-Condensing)	
Operating Altitude	Up to 5,000 meters (up to 16,400 feet or 106-54 kPa)	
Non-Operating Altitude	Up to 5,575 meters (up to 18,290 feet or 106-50 kPa)	
Shock Test (Non-Operating)	50 G, 11 ms, 3 shocks for each direction	
Vibration (Non-Operating)	5-500 Hz, 2 Grms, 15 minute for each three axis	
Acoustic Noise (Typical)	45 dB test with 80% of rated load under 30°C ²⁾	

2) Acoustic Noise test set up according to ISO-7779

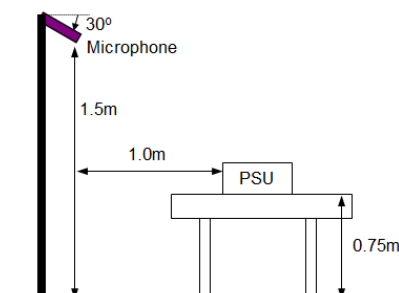

Medical / Industrial AC-DC Power Supply

750 W with 5 V / 2 A Standby / MEB-750A series

Power De-rating Curve

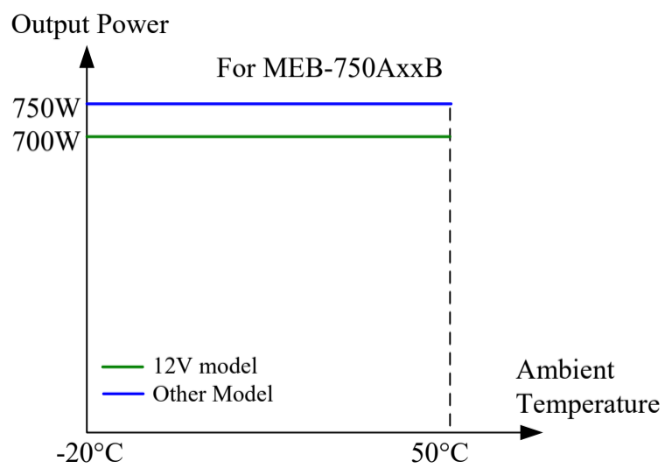
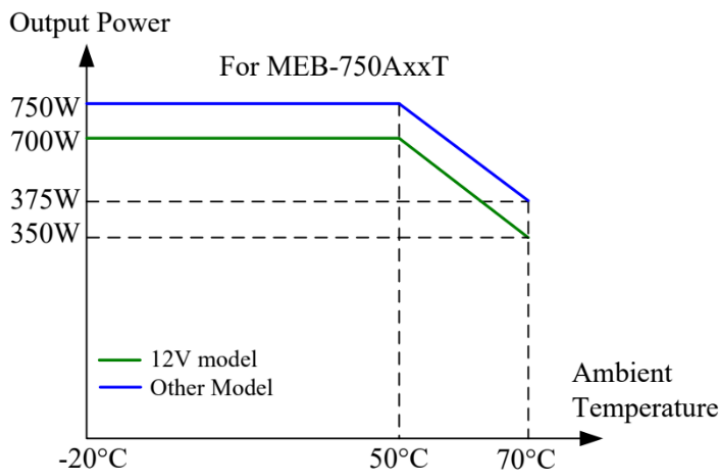
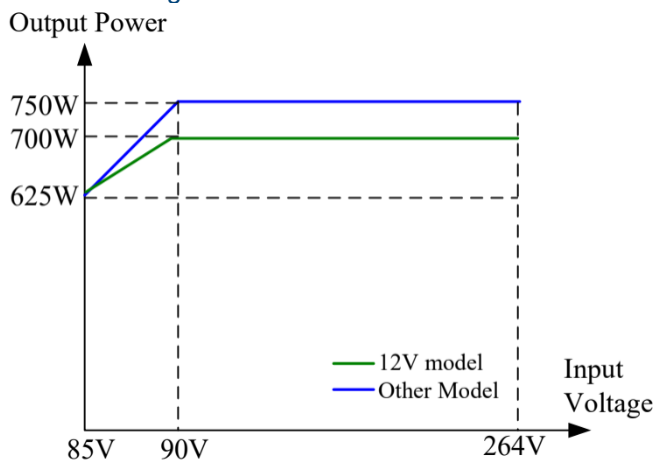

Protections (for both main output and 5Volt Standby outputs, unless otherwise indicated)

Overvoltage (max)	Main output 145% of rated normal voltage, Latch Mode Standby 125% of rated voltage, Latch Mode
Over load / Over current (max)	Main output 130% max of rated current for over 750 ms max Standby 3.2 A max with Hiccup Mode(Non-Latching, Auto-Recovery)
Over Temperature	Latch Mode for Main output
Short Circuit	Hiccup Mode for Main output and Standby (Non-Latching, Auto-Recovery)

Reliability Data

MTBF (Minimum) at 115 Vac, 750 W (700 W for 12 V) , 35 °C	500 Khrs based on Telecordia SR-332
Operating life (Minimum) at 115 Vac, 750 W (700 W for 12 V), 25°C	26,280 hrs



Medical / Industrial AC-DC Power Supply

750 W with 5 V / 2 A Standby / MEB-750A series

Safety Standards / Directives

Medical Safety	IEC 60601-1 CB report TUV EN 60601-1 ANSI/AAMI ES 60601-1+CAN/CSA-C22.2 No.60601-1						
ITE Safety	IEC 60950-1 CB report IEC 62368-1 CB report TUV EN 62368-1 TUV EN 60950-1 UL 62368-1 and CAN/CSA C22.2 No. 62368-1 CCC GB 17625.1; GB 4943.1; GB/T 9254.1 (for 24 V / 48 V model) KC/KCC (for 24V)						
Home Appliance	IEC 60335-1 CB report (for 12 V / 24 V model) IEC 61558-1 CB report (for 12 V / 24 V model) IEC 61558-2-16 CB report (for 12 V / 24 V model) TUV EN 60335-1 (for 12 V / 24 V model) TUV EN 61558-1 (for 12 V / 24 V model) TUV EN 61558-2-16 (for 12 V / 24 V model)						
CE	In conformance with EMC Directive 2014/30/EU and Low Voltage Directive 2014/35/EU EN 60601-1: 2006 + A11: 2011 + A1: 2013 + A12: 2014 & EN 60601-1-2: 2015						
UKCA	In conformance with Electromagnetic Compatibility Regulations 2016 and Electrical Equipment (Safety) Regulations 2016, Medical Devices Regulations 2002 (UK MDR 2002)						
Galvanic Isolation	<table border="1"> <tr> <td>Input to/Output (2XMOPP)</td> <td>4000 Vac</td> </tr> <tr> <td>Input to/Ground (1XMOPP)</td> <td>1500 Vac</td> </tr> <tr> <td>Output to/Ground (1XMOPP)</td> <td>1500 Vac (Type BF application rated)</td> </tr> </table>	Input to/Output (2XMOPP)	4000 Vac	Input to/Ground (1XMOPP)	1500 Vac	Output to/Ground (1XMOPP)	1500 Vac (Type BF application rated)
Input to/Output (2XMOPP)	4000 Vac						
Input to/Ground (1XMOPP)	1500 Vac						
Output to/Ground (1XMOPP)	1500 Vac (Type BF application rated)						

Medical / Industrial AC-DC Power Supply

750 W with 5 V / 2 A Standby / MEB-750A series

EMC

EMC / Emissions		EN/BS EN 55011/EN/BS EN 55032: Class B
Harmonic Current Emissions	IEC 61000-3-2	Meet Class D limit
Voltage Flicker	IEC 61000-3-3	
Immunity to		
Electrostatic Discharge	IEC 61000-4-2	Level 4 Criteria A ¹⁾⁵⁾ Air Discharge: 15 kV Contact Discharge: 8 kV
Radiated Field	IEC 61000-4-3	Criteria A ¹⁾ 80 MHz-2700 MHz, 10 V/m AM modulation Level 2 Criteria A ¹⁾⁵⁾ 385 MHz-5785 MHz, 28 V/m Pulse mode and other modulation
Electrical Fast Transient / Burst	IEC 61000-4-4	Level 3 Criteria A ¹⁾ :2 kV
Surge	IEC 61000-4-5	Level 3 Criteria A ¹⁾⁵⁾ Common Mode ³⁾ : 2 kV Differential Mode ⁴⁾ : 1 kV
Conducted	IEC 61000-4-6	Level 2 Criteria A ¹⁾⁵⁾ 150 kHz-80 MHz, 3 Vrms, 6 Vrms at ISM bands and Amateur radio bands
Power Frequency Magnetic Fields	IEC 61000-4-8	Criteria A ¹⁾⁵⁾ Magnetic field strength 30 A/m
Voltage Dips	IEC 61000-4-11	30% 10 ms Criteria A ¹⁾ 60% 100 ms Criteria B ²⁾ 100% 5000 ms Criteria B ²⁾
Voltage Dips ⁵⁾	IEC 60601-1-2	Criteria A ¹⁾ @ 650 W 0% U _T , 0.5 cycle (10 ms), (0°, 45°, 90°, 135°, 180°, 225°, 270°, 315°, 360°) Criteria B ²⁾ , can meet Criteria A with 400 W or lower load 0% U _T , 1 cycle (20 ms), 0° Criteria B ²⁾ Can meet Criteria A with 500 W or lower load 70% U _T , 25 cycle (500 ms) , 0° Criteria B ²⁾ 0% U _T , 250 cycle (5000 ms) , 0°

1) Criteria A: Normal performance within the specification limits

2) Criteria B: Output out of regulation, or shuts down during test. Automatically restored to normal operation after test.

3) Asymmetrical: Common mode (Line to earth)

4) Symmetrical: Differential mode (Line to line)

5) Compliant with IEC60601-1-2 4th Edition

Medical / Industrial AC-DC Power Supply

750 W with 5 V / 2 A Standby / MEB-750A series

Dimensions

Mechanical drawing (MEB-750AxxB)

L x W x H: 177.8 x 101.6 x 40 mm (7 x 4 x 1.575 inch)

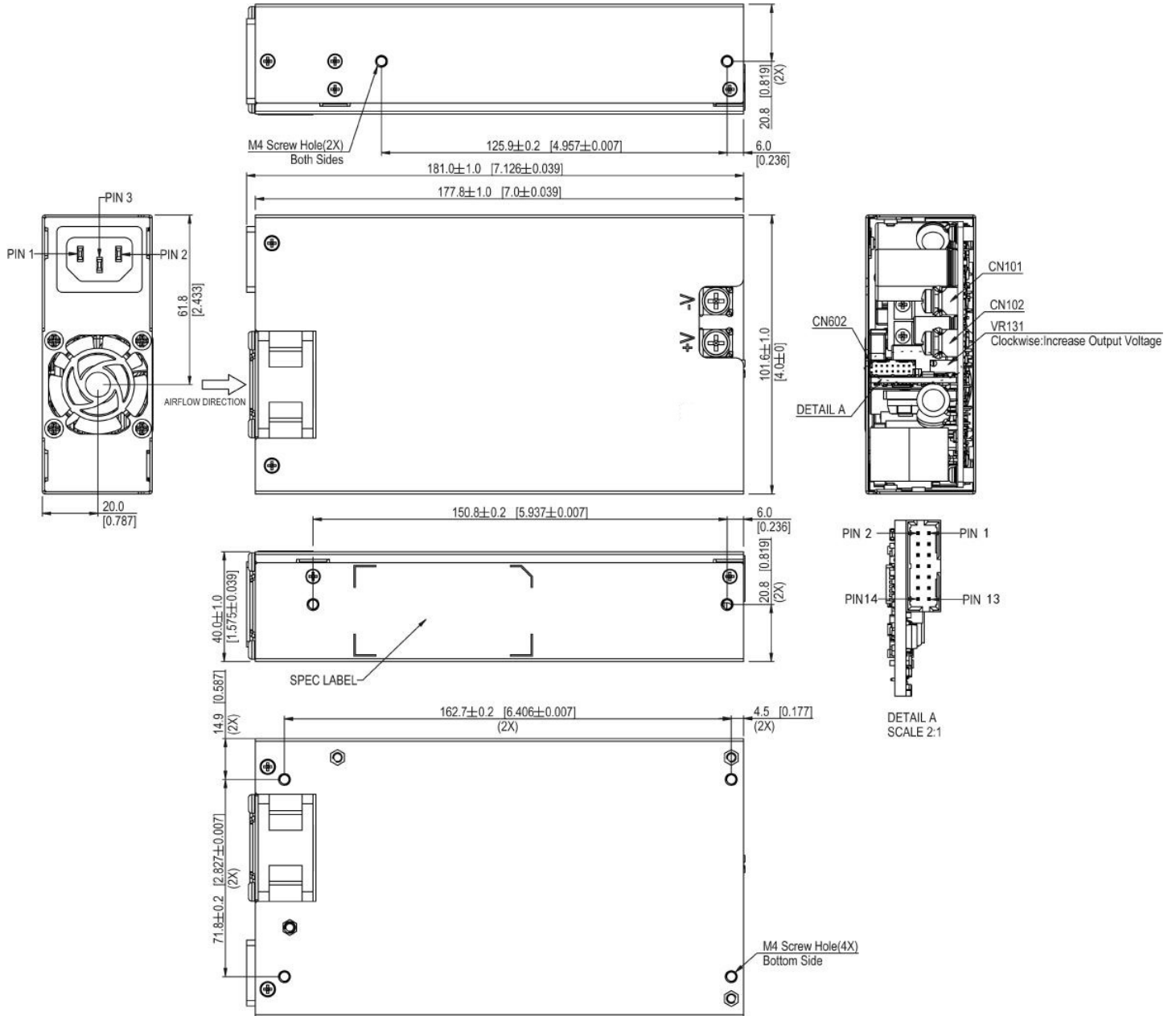

Medical / Industrial AC-DC Power Supply

750 W with 5 V / 2 A Standby / MEB-750A series

Mechanical drawing (MEB-750AXXT)

L x W x H: 177.8 x 101.6 x 40 mm (7 x 4 x 1.575 inch)

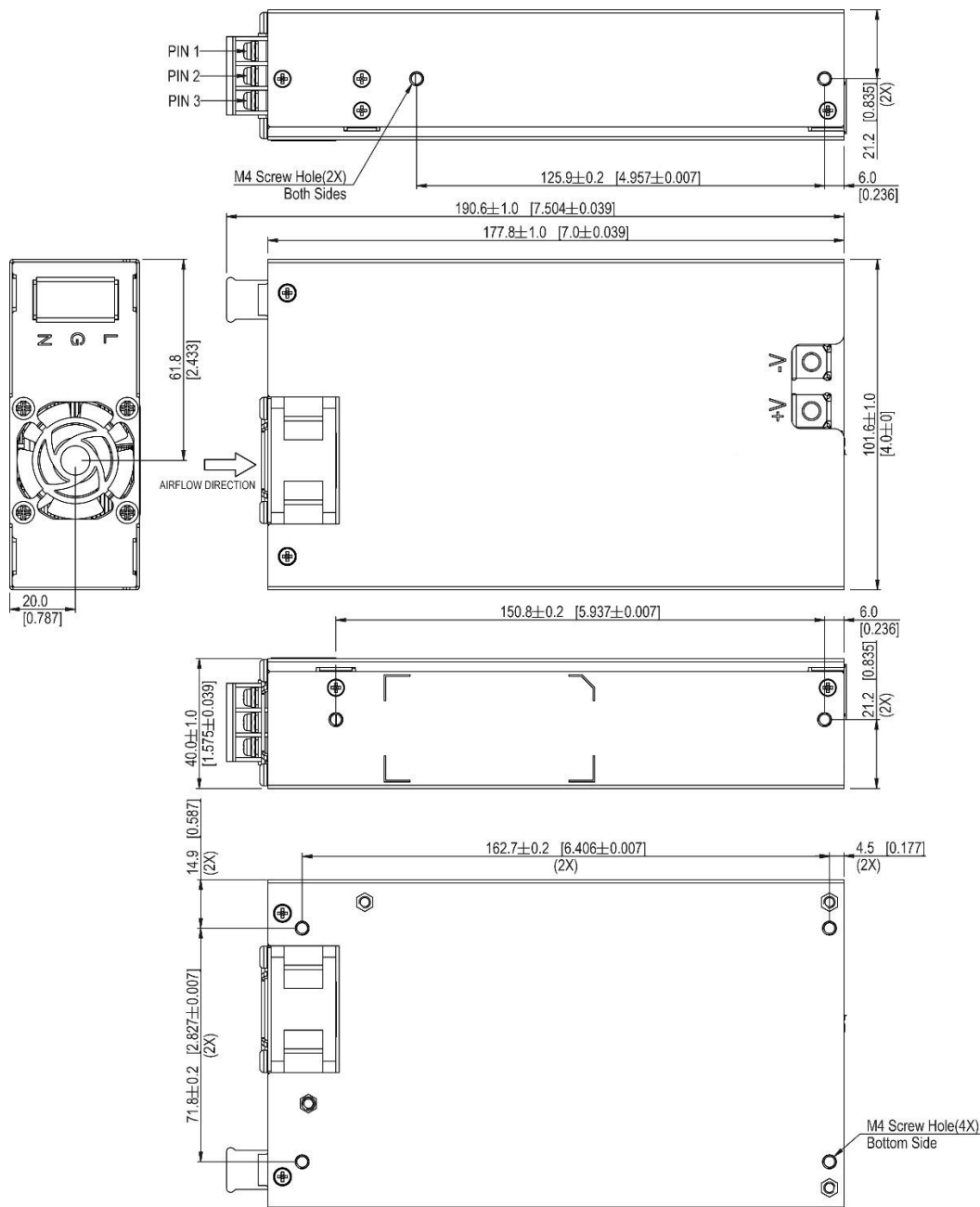

- Notes:**
1. Base plate mounting, M4 thread holes, maximum penetration 3.0 mm (0.118 inch) from outside face of chassis, maximum torque 4.5 kgf.cm (3.91 lbf.in).
 2. Side mounting, M4 thread holes, maximum penetration 3.0 mm (0.118 inch) from outside face of chassis, maximum torque 4.5 kgf.cm (3.91 lbf.in).
 3. CN101/CN102, M5 screw in two positions, maximum torque 20 kgf.cm (17.36 lbf.in).
 4. VR131: clockwise is to increase the output voltage, counter-clockwise is to reduce the output voltage.
 5. All dimensions are in millimeters and inches.
 6. Built-in cooling fan. Must prevent dust suction into power supply, or use natural convection power supply if any concerns.

Medical / Industrial AC-DC Power Supply

750 W with 5 V / 2 A Standby / MEB-750A series

AC Inlet Type Option

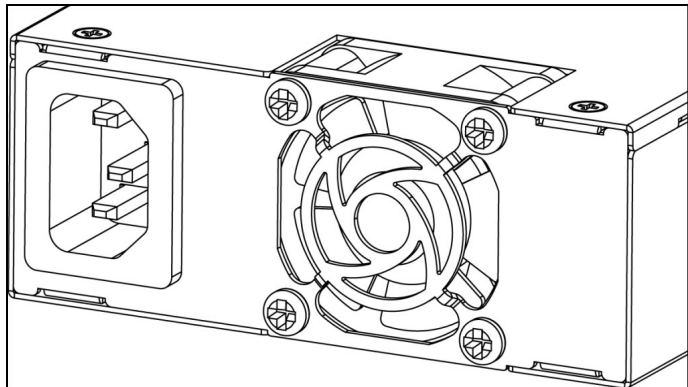

IEC320 C14

Conductor size: AWG 20 to 14
Mating with IEC320 C13

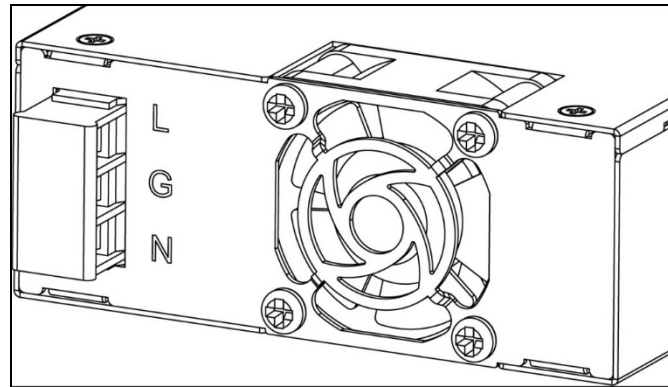

American Barrier Strip

Conductor size: AWG 20 to 14.
Tightening torque: 8 kgf.cm.

Connector Definition and Pin Assignment

Input Connector		
	MEB-750AXXB (IEC320 C14)	MEB-750AXXT (American Barrier Strip)
Pin 1	AC Neutral	AC Line(Phase)
Pin 2	AC Line(Phase)	Ground
Pin 3	Ground	AC Neutral
Output Connector		
CN101	DC RTN	
CN102	Vo	
Control Connector CN602(Cvilux:CI0114P1HD0-NH) Mating With Cvilux:CI0114SD000 Terminal:CI01TD21PE0		
Pin 1	Current Share	
Pin 2	DC RTN	
Pin 3	Remote Sense +	
Pin 4	Remote Sense -	
Pin 5	DC RTN	
Pin 6	DC RTN	
Pin 7	5V Standby Output +	
Pin 8	5V Standby Output +	
Pin 9	NC	
Pin 10	NC	
Pin 11	Power Good-	
Pin 12	Power Good+	
Pin 13	Remote On_Off/Inhibit +	
Pin 14	Remote On_Off/Inhibit -	

Medical / Industrial AC-DC Power Supply

750 W with 5 V / 2 A Standby / MEB-750A series

Functions

Start-up Time

The time required for the output voltage to reach 90% of its final steady state value, after the input voltage is applied.

Rise Time

The time required for the output voltage to change from 10% to 90% of its final steady state value.

Hold-up Time

Time between the collapse of the AC input voltage, and the output falling to 90% of its steady state value.

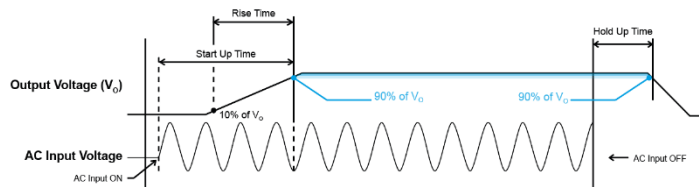

Figure 6. Time Sequence

Dynamic Response (Main Output)

The power supply output voltage will remain within $\pm 5\%$ of its steady state value, when subjected to a dynamic load 50 to 100% of its rated current.

■ 50 to 100% Load

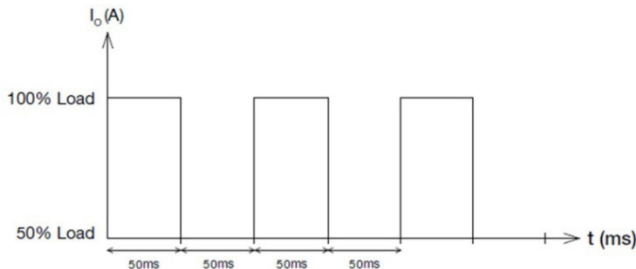

Figure 7. Dynamic Load

Inrush Current

Inrush current is the input current that occurs when the input voltage is first applied. For AC input voltages, the maximum peak value of inrush current will occur during the first half cycle of the applied AC voltage. This peak value decreases exponentially during subsequent cycles of AC voltage.

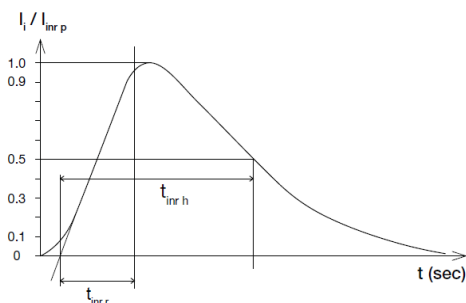

Figure 8. Inrush Current

Overvoltage Protection

The power supply's overvoltage circuit will be activated when its internal feedback circuit fails. The output voltage shall not exceed its specifications defined on Page 5 under "Protections". Power supply will latch off, and require removal/re-application of input AC voltage in order to restart.

Overload & Over current Protections

The power supply's Overload (OLP) and Over current (OCP) Protections will be activated before output current under 130% of I_o (Max load) for over 750ms max. Upon such occurrence, V_o will start to drop. Once the power supply has reached its maximum power limit, the protection will be activated and the power supply will go into "Hiccup mode" (Auto-Recovery). The power supply will recover once the fault condition causing the OLP and OCP is removed and I_o is back within the specified limit.

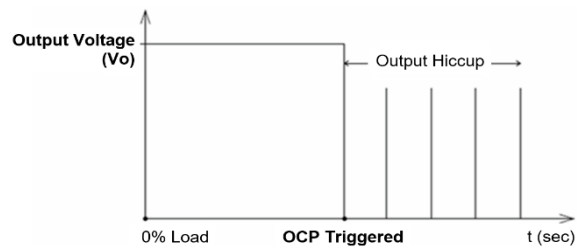

Figure 9. Hiccup at OLP/OCP

Additionally, if the I_{out} is $>100\%$ for a prolonged period of time (depending on the load), the Over Temperature Protection (OTP) may be activated due to high temperature on critical components. The power supply will then go into latch mode.

Short Circuit Protection

Output OLP/OCP function also provides protection against short circuits. When a short circuit is applied, the output current will operate in "Hiccup mode", The power supply will return to normal operation after the short circuit is removed.

Over Temperature Protection

As mentioned above, the power supply also has Over Temperature Protection (OTP). This is activated when the overload condition persists for an extended duration and the output current is below the overload trigger point but $>100\%$ load. In the event of a higher operating temperature condition at 100% load, the power supply will run into OTP when the surrounding air temperature is higher than the operating temperature. When activated, the output voltage will go into latch mode until the input voltage is removed; then, reapplied, and the surrounding air temperature drops to its normal operating temperature.

Medical / Industrial AC-DC Power Supply

750 W with 5 V / 2 A Standby / MEB-750A series

Power Good

Power Good+/- pin is an isolated open collector transistor (80 V/50 mA rating). A resistor (suggested value 10 Kohm, 1/8 W) can be added between Power Good- pin and DC RTN, Power Good+ pin can be connected to 5 V standby (or, other available pull-up voltage that is no greater than the transistor rating). Value of resistor may have to be adjusted, depending on voltage used, and other end-use conditions of the Power Good+ pin connection to the product. When AC input is on, Power Good Signal (Shown in below figure) generated will be high. When AC input is off, Power Good Signal generated will be low. There will be a minimum of 5 milliseconds (at 1000 W load) between the time the Power Good Signal goes to low level, and the time when the output reaches 90% of its rated value.

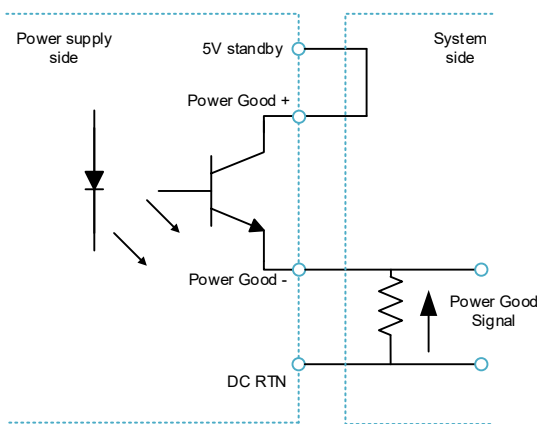

Figure 10. Power Good Connection

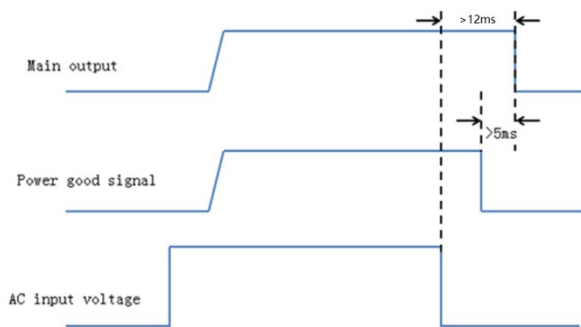

Figure 11. Power Good Time Sequence

Remote On_Off/Inhibit

Remote ON_OFF/INHIBIT uses an isolated diode located within the power supply. This signal can be used to enable or disable only the main output. When the main output is disabled, the +5 V Standby output will continue to operate. System can use a switch to conduct through this diode (suggested pull up resistor to 5 V standby with 1 Kohm resistor) to disable the main out. The signal can be floated (no connection to the signal), in order to enable the main output.

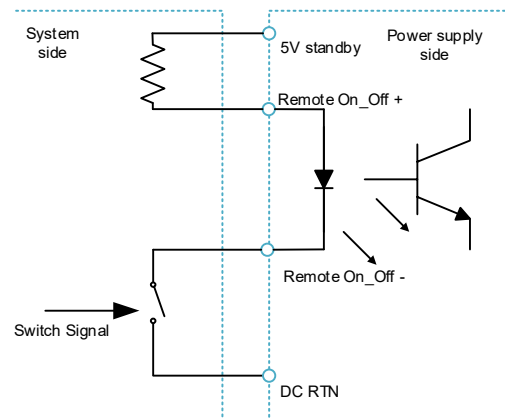

Figure 12. Remote On_Off Connection

Remote Sense

Remote sense feature can be used to compensate for the extra voltage drop on output wires that are connected from the main output terminals, to the load. With wires connected from the remote sense pins, at the same locations as the wires from the main output, the remote sense function can compensate up to 500mV voltage drop. The power supply will not be damaged if the remote sense pins are shorted, or if a reverse/inverted polarity connection is made to the load.

Voltage Adjustment

The power supply provides a potentiometer for user to adjust the output voltage. When the output is adjusted below nominal value, the maximum output current is the same as the nominal output, when the output is adjusted above nominal value, the output power cannot exceed the nominal maximum power (the maximum output current will be reduced accordingly).

Current Sharing

The power supply supports current sharing. Parallel the outputs as well as the current sharing bus to enable this feature. To ensure better current sharing performance, use VR to trim output voltage as close as possible before put two power supplies in parallel.

Medical / Industrial AC-DC Power Supply

750 W with 5 V / 2 A Standby / MEB-750A series

Certificate



Delta has been certified as meeting the requirement of ISO 13485: 2003 and EN ISO 13485:2012 for the design and manufacture of switching power supply and adaptor for medical device.



In addition to a UL Total Certification Program (TCP) approved client laboratory for IEC60950 and IEC60065. Delta also has participated UL Client Test Data Program (CDTP) for IEC 60601

Attention

Delta provides all information in the datasheets on an "AS IS" basis and does not offer any kind of warranty through the information for using the product. In the event of any discrepancy between the information in the catalog and datasheets, the datasheets shall prevail (please refer to www.DeltaPSU.com for the latest datasheets information). Delta shall have no liability of indemnification for any claim or action arising from any error for the provided information in the datasheets. Customer shall take its responsibility for evaluation of using the product before placing an order with Delta.

Delta reserves the right to make changes to the information described in the datasheets without notice.

Manufacturer and Authorized Representatives Information

Manufacturer

Thailand

Delta Electronics (Thailand) PCL.
909 Pattana 1 Rd., Muang, Samutprakarn, 10280 Thailand

Taiwan

Delta Electronics, Inc.
3 Tungyuan Road, Chungli Industrial Zone, Taoyuan County
32063, Taiwan

Authorized Representatives

The Netherlands

Delta Greentech (Netherlands) B.V.
Zandsteen 15, 2132 MZ Hoofddorp, The Netherlands

United Kingdom

Delta Electronics Europe Limited
1 Redwood Court, Peel Park Campus,
East Kilbride, Glasgow, G74 5PF, United Kingdom